

**Checkpoint 1  
Handout C1**

**Unit 1  
All About School**









**A** Write the information on your backpack tag.



My name is \_\_\_\_\_  
 I am \_\_\_\_\_ years old. I am in grade \_\_\_\_\_.  
 My English teacher's name is: \_\_\_\_\_  
 My favourite subject at school is: \_\_\_\_\_

**B** Write the school supplies you need for your English class.

For English class, I need...

1. <u>one highlighter</u>		2. _____	
3. _____		4. _____	
5. _____		6. _____	
7. _____		8. _____	

**Words**

gym • library • lunchroom •  
 principal's office • secretary's office





**C** Answer the questions.  
 Write complete sentences.  
 Use the **Words** in the box.

- Where is the secretary? The secretary is \_\_\_\_\_
- Where is the gym teacher? \_\_\_\_\_
- Where are the books? \_\_\_\_\_
- Where is the principal? \_\_\_\_\_
- Where do you eat your lunch? \_\_\_\_\_





**Checkpoint 2  
Handout C2**

**Unit 2  
Good Morning!**

- A** Look at the illustrations.  
**Decide** if the breakfast is healthy or not healthy.  
**Write** the names of the foods.

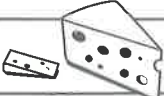
<p>1. </p>	<p>This breakfast is _____. It has a _____, _____ and _____.</p>
<p>2. </p>	<p>This breakfast _____</p>
<p>3. </p>	<p>_____</p>
<p>4. </p>	<p>_____</p>
<p>5. </p>	<p>_____</p>

- B** Find a classmate who likes the breakfast food.  
**Ask** a classmate: Do you like...?  
**Write** the classmate's name.

Breakfast food	Classmate's name
<p>1. eggs </p>	
<p>2. cheese </p>	
<p>3. mushrooms </p>	
<p>4. bananas </p>	
<p>5. maple syrup </p>	
<p>6. tomatoes </p>	

**Checkpoint 3  
Handout C3**

**Unit 3  
Backyard Animals**

**Words**

antenna • beak • ear • eye • feather • leg • nose • paw • tail • wing

**A** Write the name of the body parts in the boxes.  
Use a or an.

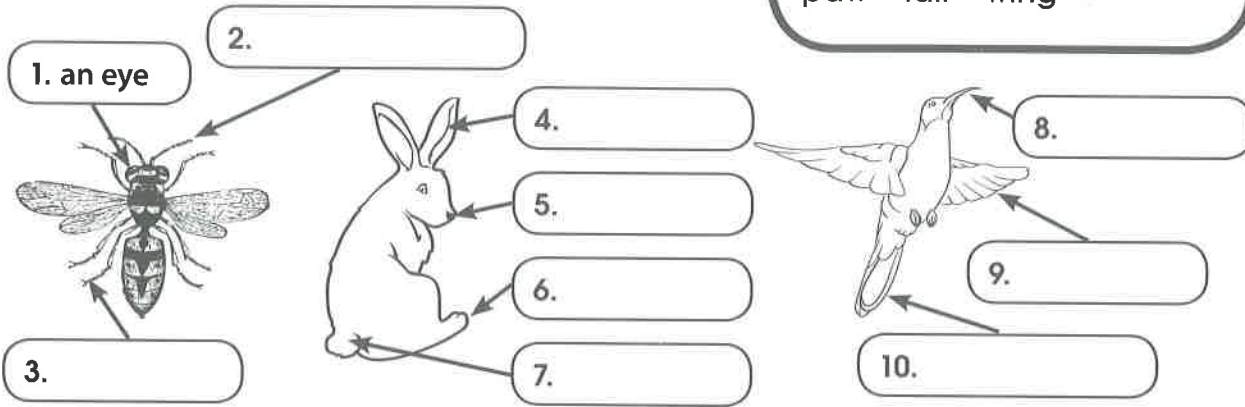



**B** Write the names of animals to complete each sentence.  
Use the **Words** in the box for help.

**Words**

rabbit • mouse • skunk • ladybug • caterpillar • spider • frog • snake • butterfly

- A rabbit has long ears. A \_\_\_\_\_ has small ears.
- A \_\_\_\_\_ has a long tail. A \_\_\_\_\_ has a short tail.
- A \_\_\_\_\_ has big wings. A \_\_\_\_\_ has small wings.
- A \_\_\_\_\_ has short legs. A \_\_\_\_\_ has long legs.
- A \_\_\_\_\_ has big eyes. A \_\_\_\_\_ has small eyes.

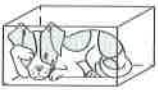
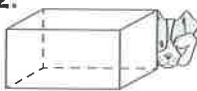
**C** Complete the sentences with in, on, in front of or behind.

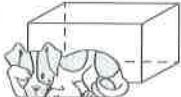
1. 	The dog is _____ the box.	2. 	The dog is _____ the box.
3. 	The dog is _____ the box.	4. 	The dog is _____ the box.

**Checkpoint 4**  
**Handout C4**

**Unit 4**  
**Ahoy! Welcome Aboard**

**A** Replace the underlined words in each sentence with he or she.

1. The girl is on the pirate ship. \_\_\_\_\_ is on the pirate ship.
2. The boy walked the plank. \_\_\_\_\_ walked the plank.
3. Blackbeard is a dangerous pirate. \_\_\_\_\_ is a dangerous pirate.
4. Emma wears a kerchief. \_\_\_\_\_ wears a kerchief.
5. Jack Sparrow is a popular pirate. \_\_\_\_\_ is a popular pirate.

**B** Read the model.

**Colour** the circle with the colour you choose.

**Write** sentences to describe your colours and the clothing in the illustrations.

**Use** he or she.

Model



He wears a yellow belt.

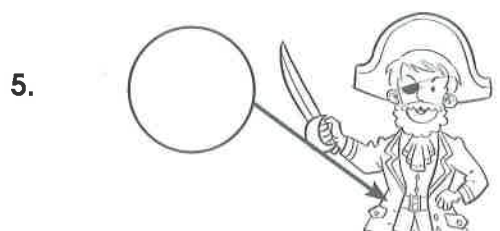
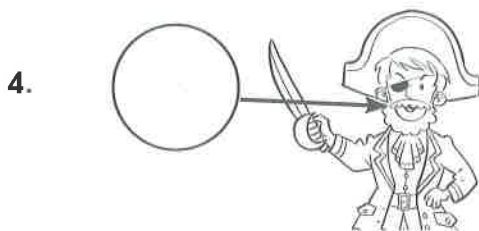
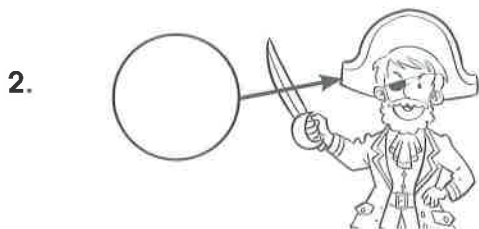
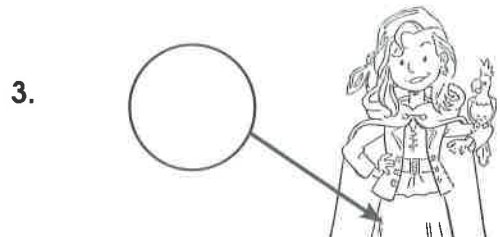
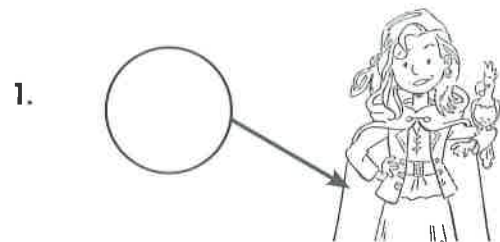

**Checkpoint 5**  
**Handout C5**

**Unit 5**  
**The Doctor Is In**



**A Complete** the sentence with have or has.

1. Emma \_\_\_\_\_ a sore throat.
2. Billy and Emma \_\_\_\_\_ fevers.
3. I \_\_\_\_\_ a broken arm.
4. My father \_\_\_\_\_ a headache.
5. Judy Moody \_\_\_\_\_ a brother called Stink.
6. Mr. Todd \_\_\_\_\_ a skeleton in his class.
7. Frank \_\_\_\_\_ a gold fish.
8. Frank, Jessica and Rocky \_\_\_\_\_ pet animals.

**B Read** the story.

**Place** the sentences in the correct order, from 1 to 4.

Emma is not feeling good. She is sad because she has a sore throat. Her throat hurts when she eats. Her mother prepares chicken and noodle soup for Emma. She tells Emma to drink a lot of water. Emma is happy because she loves chicken and noodle soup. After dinner, Emma chooses her favourite movie. She watches the movie in her mother's bed. Emma falls asleep!

- Emma eats chicken and noodle soup and drinks water.
- Emma has a sore throat.
- Emma falls asleep.
- Emma watches a movie.

**Checkpoint 6**  
**Handout C6**

**Unit 6**  
**Four Seasons of Fun**

**A** Look at the underlined words in the answer (A).  
Complete each question (Q) with the correct question word: Who, Where, What

- |                                |   |
|--------------------------------|---|
| 1. Q: _____ is in the bedroom? | A: <u>Billy</u> is in the bedroom.        |
| 2. Q: _____ is Emma?           | A: Emma is <u>in the living room</u> .    |
| 3. Q: _____ is Mr. Cat doing?  | A: Mr. Cat is <u>sleeping</u> .           |
| 4. Q: _____ is Billy doing?    | A: Billy is doing <u>his homework</u> .   |
| 5. Q: _____ is in the kitchen? | A: <u>Billy's dad</u> is in the kitchen.  |
| 6. Q: _____ is Grandma?        | A: Grandma is <u>in the backyard</u> .    |
| 7. Q: _____ is Nathan doing?   | A: Nathan is <u>playing video games</u> . |
| 8. Q: _____ is Nathan?         | A: Nathan is <u>in the basement</u> .     |

**B** Complete the sentences.  
Use is or are.

- |                                  |                                    |
|----------------------------------|------------------------------------|
| 1. The boys _____ playing.       | 2. Grandma _____ making dinner.    |
| 3. Billy's father _____ reading. | 4. Nathan and Billy _____ skating. |
| 5. Mr. Cat _____ eating.         | 6. He _____ skateboarding.         |
| 7. They _____ flying a kite.     | 8. She _____ raking leaves.        |

**C** Work with a classmate.

**Tell** your classmate the activities you like to do for each season.  
**Write** your classmate's answers.

- In the summer, my classmate likes to \_\_\_\_\_
- In the fall, \_\_\_\_\_
- In the winter, \_\_\_\_\_
- In the spring, \_\_\_\_\_

**Checkpoint 7**  
**Handout C7**

**Unit 7**  
**Vacation Time**

- A** **Read** about Emma and Billy’s summer plans.  
**Underline** where Emma and Billy will go this summer.

**Emma:** Hi, Billy. Soon it will be summer vacation.

**Billy:** Where will you go this summer, Emma?

**Emma:** I will go to Lake Champlain for two weeks in July. My uncle has a beach house and a sailboat there.

**Billy:** That sounds like fun!

**Emma:** Where will you go?

**Billy:** In July, I will go to the beach with my little cousin Sebastian.

**Emma:** That’s fun!

**Billy:** Where will you go with your family in August?

**Emma:** In August, my family and I will go to Ottawa for two weeks. We go every summer. We will visit the Canadian Museum of Nature. We always go to the Museum of Nature! I’m bored at the Museum of Nature.

**Billy:** You’re bored! You’re so lucky, Emma! I will go to the park to see nature.

- B** **Complete** the chart with information from the dialogue.

Who?	When?	Where?
Emma		
		The beach
	In August	
Billy		
		Canadian Museum of Nature